

# Situation

## 'Design Task 10

**People have an increasing number of gadgets and gizmos in their homes, such as mobile phones, iPods, remote controls, hand held computer games etc. Many of these products need chargers, memory cards, games etc. Design and make a gadget tidy.'**

**Brief:** I am using this controlled assessment task (number 10) as the basis for my controlled assessment coursework where I will be designing and making an innovative gadget tidy, able to store multiple cables, a phone and things such as ear phones.

I have decided to pick this project as I myself suffer from way to many memory cards, cables and phones, and wishing for a product specifically designed to store gadgets such as mine.

I believe that my product will be aimed at anyone who is modern and in the age range of 15-30, and also use quite a lot of gadgets e.g. Cameras so that they will have a lot of memory cards which need storage.

**Summary:** I have learnt some things I want in my design and who I want it to be aimed at.



# Existing Products



I got this picture from:  
[http://technabob.com/blog/wp-content/uploads/2008/06/sanctuary\\_gadget\\_organizer.jpg](http://technabob.com/blog/wp-content/uploads/2008/06/sanctuary_gadget_organizer.jpg)

## Good Points:

This tidy looks neat and still quite stylish, it would be difficult for any of the products to slip out.

## Bad Points:

The tidy looks very specific for which products can be stored in it and not that mobile.

## Good Points:

I find this quite a modern form of gadget tidy/storage unit. It is unique and innovative. The product can adapt to any product and wrap itself around it to store literally any gadget.

## Bad Points:

While being unique it does not look exceptionally secure, only being a sheet of material it would not wrap around it securely enough which would cause a lot of problems.



I got this picture from:  
<http://www.chipchick.com/wp-content/uploads/2009/03/geargripper.jpg>

**Summary:** I have learnt that the design needs to be solid but still light and capable of being moved around, also the design should be able to hold any kind of gadgets not specific ones.

# Existing Products



I got this picture from:  
<http://www.2dayblog.com/images/2007/january.jpg>

## Good Points:

This design is quite good as it can fit in a multitude of gadgets as well as being able to charge the gadgets, this gadget tidy is very versatile.

## Bad Points:

Bad points of the design are that it would only be able to fit about 4 or 5 gadgets.

## Good Points:

This is what I would call the definition of a gadget tidy, it is sleek, attractive and open. The tray at the top is open which allows it to store many different kinds of gadgets and still seem modern. It also has very nice looking drawers which can store a number of different gadgets. the tidy is also made of wood which makes it environmentally friendly.

## Bad Points:

The bad points about this product would be that the drawers are quite thin and would not be able to store gadgets that are slightly thick.



I got this picture from:  
<http://www.pacificgeek.com/productimages/xl/WBP400-2.jpg>

# Existing Products



I got this image from:  
<http://www.fonearena.com/blog/26925/the-regun-luxury-table-tidy-organizes-your-desk-clutter.html>

## Good Points:

The tidy is quite open and can fit a few different types of gadgets. It is simple yet very effective and does the job well.

## Bad Points:

The design is still limited to only 3 or 4 gadgets/cables and even then is limited to a few certain kinds of gadgets (Mobile phones again).

## Good Points:

I like this design as while being a bit limited, it is open and gives a small freedom of choice for the what the owner wants to store.

## Bad Points:

While being open 3 of the 4 storage compartments are limited to mobile phone shaped items, I want to stay away from this method of designing by trying to keep my storage as open as possible.



I got this image from:  
[http://www.chipchick.com/2008/05/pastel\\_colored\\_mini\\_charging\\_valet\\_keeps\\_your\\_gadgets\\_tidy.html](http://www.chipchick.com/2008/05/pastel_colored_mini_charging_valet_keeps_your_gadgets_tidy.html)

# What I've Learned

I want my design to be as open as possible, I don't want my gadget tidy to be only built for phones (even if they are the most popular gadget). I want my tidy to be open and accept a number of gadgets.

Good



These tidy's are: modern, open, simple and nice. These are all the qualities I want in a tidy and they have really helped me picking my specifications and what I want my design to look like.

Bad



These tidy's are: specific, closed and too simple. I want my tidy to be able to hold a lot of gadgets/cables as well as being able to hold many different kinds. These tidy's are what I would like to stay away from.

# My Specifications

Needs to be:

- **Strong**

I want my tidy to be able to take a few accidental blows.

- **Attractive kind of wood**

I'm making it out of wood because of the environment, as wood is an environmentally sustainable material.

- **Open**

I don't want to have any kind of annoying drawers and it needs to be spacious.

- **Able to store anything, to not be too specific on which electrical gadgets I store**

After reviewing a lot of gadget storage units I find they are too specific in what products to store.

- **Smooth, not have any splinters**

I wouldn't want my tidy to give out any sharp splinters.

- **To be able to fit something as big as a sky remote**

This is the largest product that I would like to fit in my tidy so if it can fit a sky remote it can fit anything.

Having seen and reviewed a few good designs of gadget tidies my conclusion is:

- My gadget tidy needs to be able to store a lot of things while still being easy to carry around and move.
- It should not be specific to any gadgets, it should have some form of open storage.
- The tidy should not be made of any flexible material and be solid.

**Summary:** I have learnt what I would like my gadget tidy to be like, what it does and how it looks.



I got this picture from : <http://www.forevergeek.com/wp-content/uploads/2009/06/sky-tv-remote-original.jpg>

# Initial Ideas

## Compared to specifications:

### Good Points

- Being made of wood it is quite strong and could take some dents.
- Can be made of any wood.
- This is the most open initial idea I have, having large shelves for large gadgets.
- With this being the most open of my initial ideas, it could easily fit a sky remote.

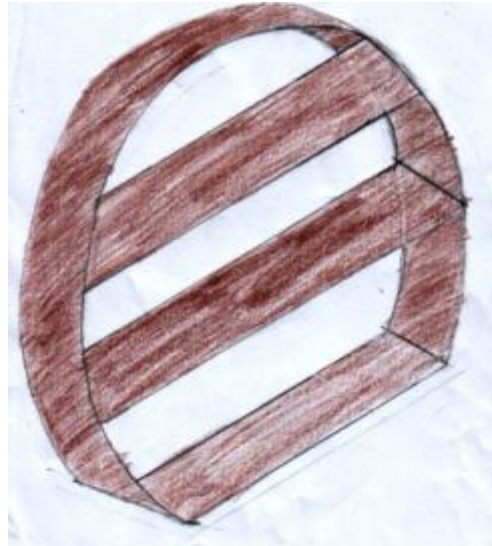

This idea is quite simple, but very effective and can store anything, the idea would definitely need development to be more modern and original.

## Compared to specifications:

### Bad Points

- Gadgets could fall through the back of the design.
- Unless built incorrectly it could splinter.

**Summary:** These are my initial ideas, I have analysed all 3 of them and have chosen my first design, all though just a basic drawing I believe that once put into 2D Design it would have a lot of potential.

# Initial Ideas

This might seem quite simple, but would be the size of a small coffee table, having a tray at the top to store anything and 3 separate draws to store other gadgets.

## Compared against specifications:

### Good Points

- With it being a box it will be quite sturdy.
- With a tray it is quite open.
- With the tray it can store multiple things, the draws might limit that.
- It shouldn't splinter if made correctly.
- The tray could possibly fit a sky remote depending on how large the tray is.

### Bad Points:

- Not original or inspired.

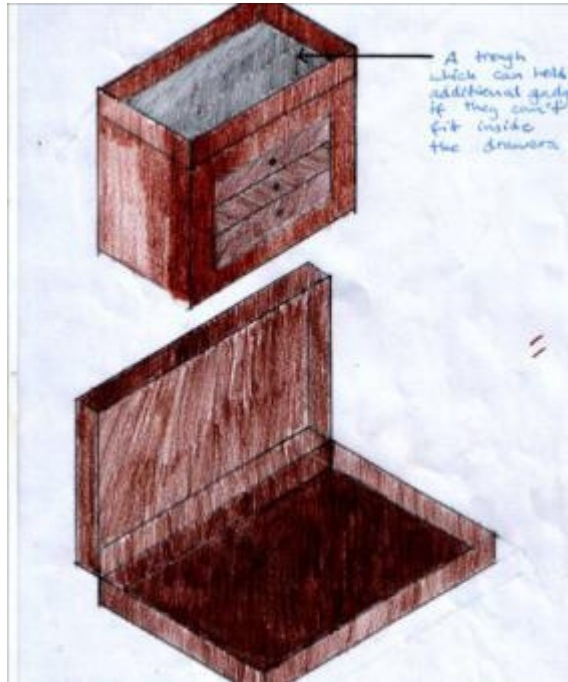

This is my first idea, although 3 simple shelves it is quite modern and would have potential to be very effective at storing gadgets.

## Compared against specifications:

### Good Points

- Quite sturdy if thick enough
- Can be open if the lid is left up
- Not specific at all
- Depending on how it's made depends on if it splinters.
- Could fit a sky remote depending on scale

### Bad Points

- Very simple, could barely fit anything inside unless they were very flat gadgets.
- Would need to be quite large to be effective.

# Development of initial idea

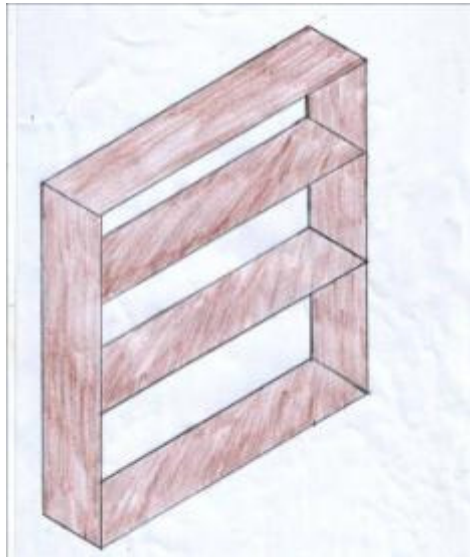

This is my basic idea. I want it to be similar to a small shelf and quite open to give the owner freedom of choice with what they want to put into the design. I don't want them to be limited to only a very specific type of gadget can fit into a specific slot.

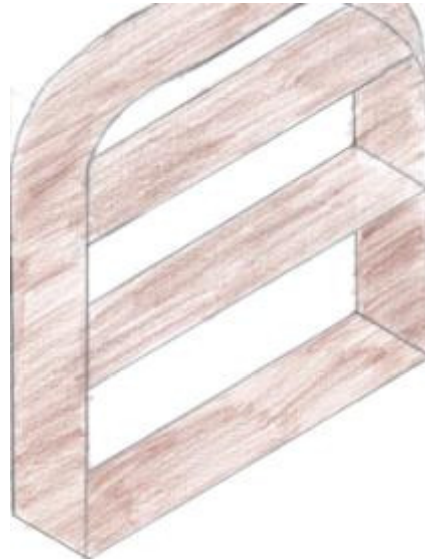

This is an improved version of my most basic idea. I want my idea to have the element of being similar to a shelf while still appearing to be modern and open.

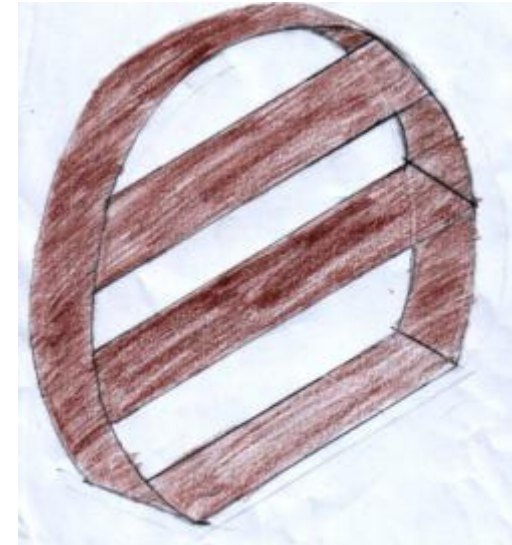

This is my final basic design. Here you can see that in the the process of making it more circular I have increased the size the shelf to give more freedom for choice and to fit for 2 of my specification criteria. I feel it being circular that it is a lot more modern.

# My Initial Idea



This is my initial idea, and it looks promising, as well as modern which would fit my specifications well. A problem I could foresee would be that the gadgets could possibly fall through the back of the design.

This would be tested when I make my model and possibly amended for the future product if it would be a problem.



Another problem I could see occurring could be that when a gadget is pushed into the tidy the tidy could fall backwards. A possible solution to amend this problem would be to cut out a section of the base and to slide a piece of wood underneath ( it would still look quite modern if it was made of the same type of wood), this would go through the front and back so it couldn't call forwards or backwards.

# Implications

## **Social**

Ever since my design is going to be 'open' then it can be used for more than just gadgets unlike other gadget tidies it can hold jewelry as well as other miniscule things so it reaches out to be who don't just have lots of gadgets.

## **Sustainability**

The original design is to be made of wood and possibly be painted/varnished the only sustainability problems I could see would be if I painted/varnished it would be whether I could source environmentally friendly substances if I were to put it into mass production

## **Target Market**

I believe that my target market is anyone between 15-30 years old as these are the people who have multitudes of electronic gadgets. However my design can suit anyone of any age who has any form of electronic gadgets, or as stated before any other forms of miniscule objects.

## **Environment**

I am making my gadget tidy out of wood (Ash Wood) as wood is a very environmentally sustainable product.

This would advertise itself a lot more if I were to mass produce it for sale as it is environmentally friendly, easy to use and cannot dent or scratch any forms of product put inside the gadget tidy.



# My Model

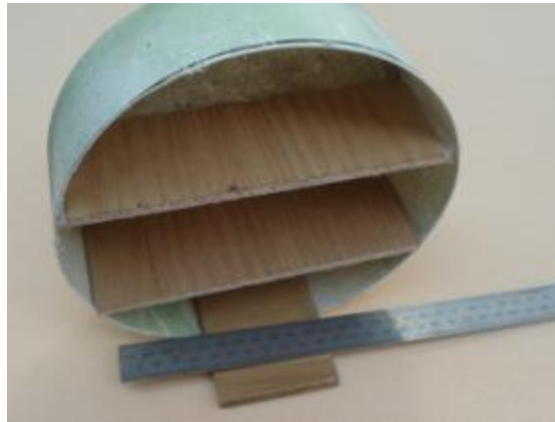
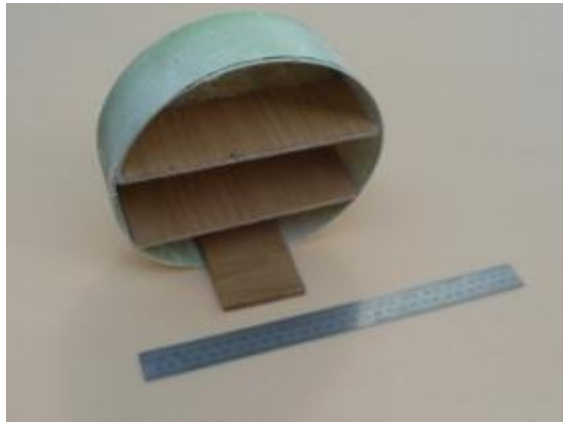

This is my model. It is 3cm diameter smaller than my specifications, which made me think my design would be too small for my specifications, on review I realised that my actual design would fit my specifications well. I also added a back so that any gadgets pushed to the back would not fall out. Once my design was made I filled it with some simple, light, models for large iPods, and what I noticed was that the model would lean forward, this was a problem because the iPods I filled it with were very light and the model still leaned forward.

This is why a balance block would be needed on the bottom of my project or it could fall over and potentially damage the gadgets inside.

While the entire project would be made of the wood. The glue/paint/varnish could not be environmentally friendly.

If I were to produce my project in higher quantities I would at least attempt to source environmentally friendly paint/varnish e.g. One that degrades over time.

Also dividers would be added on the top and bottom shelves so that it would seem more modern and not many things would be mixed up in the top and bottom shelves.

# Parts List

Part Number	Part Name	Number Off	Cross Section	Length in metres	Material	Cost per Metre	Total Cost	
1	Back Disk	1	250	0.012	Ash	£0.00	£2.18	
2	Front Disk	1	250	0.012	Ash	£0.00	£2.18	
3	MDF Layer 1	1	250	0.012	MDF	£0.00	£0.48	
4	MDF Layer 2	1	250	0.012	MDF	£0.00	£0.48	
5	MDF Layer 3	1	250	0.012	MDF	£0.00	£0.48	
6	MDF Layer 4	1	250	0.012	MDF	£0.00	£0.48	
7	MDF Layer 5	1	250	0.012	MDF	£0.00	£0.48	
8	MDF Layer 6	1	250	0.012	MDF	£0.00	£0.48	
9	MDF Layer 7	1	250	0.012	MDF	£0.00	£0.48	
10	MDF Layer 8	1	250	0.012	MDF	£0.00	£0.48	
11	Veneer	1	800	0.012	Ash	£8.58	£0.82	
12	Dowel	3	60	0.108	Ramin	£0.60	£1.80	
13	Base	1	120	0.015	Ash	£0.00	£1.97	
							<b>Total</b>	£10.86

I used Microsoft excel to make this table

# Making my project

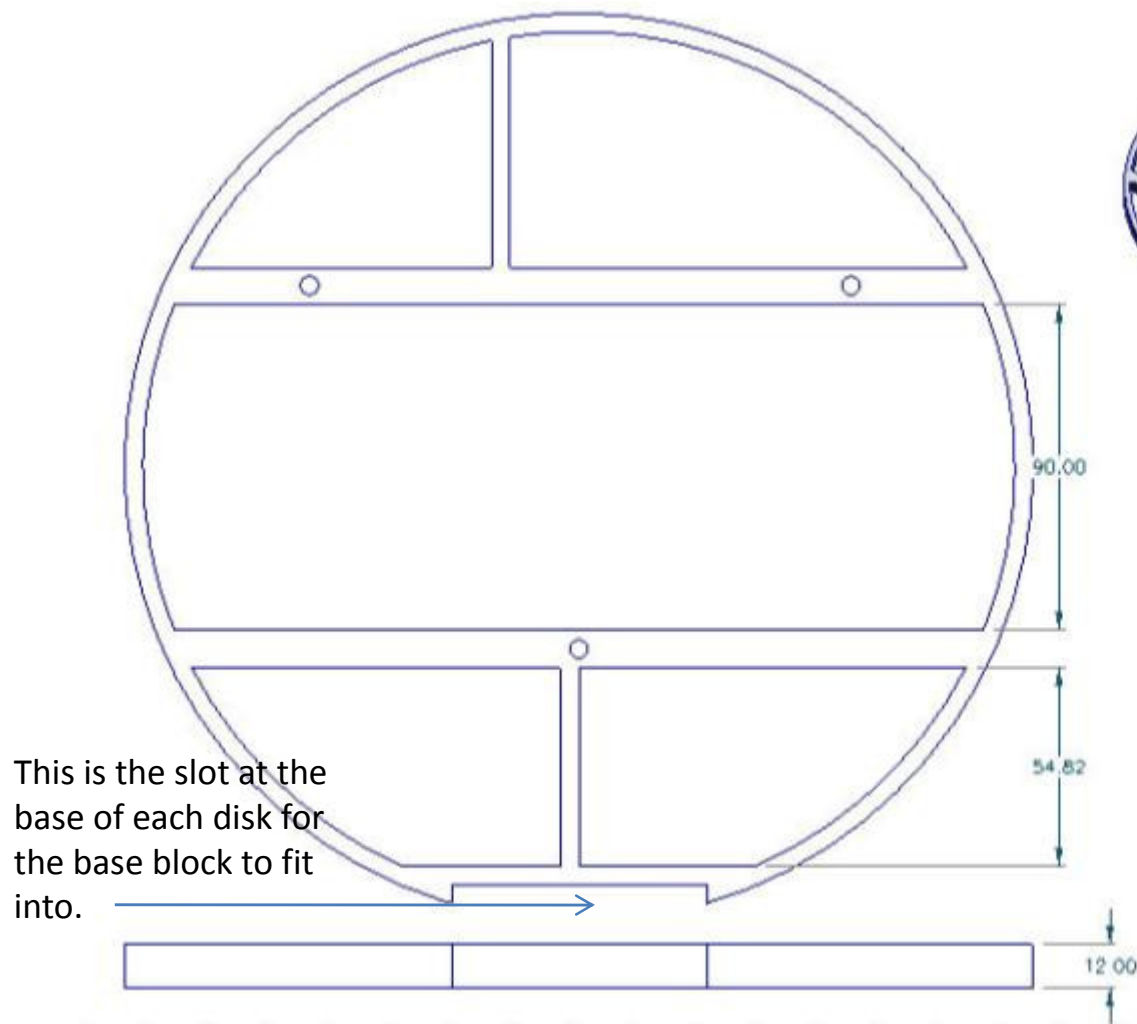

This is one of my 10 “disks” that stack together to make my design (each being 12mm thick to make up my design of 120mm thick), 8 of them being made of MDF (Medium Density Fibre), and 2 for them being of solid wood (Ash). This shows the frontal view, and the plan view, as well as an angled view.

Also my design will involve a wooden block as a base so it shouldn't fall backwards or forwards.

# Plan of Making

**Step 1:** Firstly, I will begin by taking 10 sheets of MDF and putting them into the CNC machine to cut them to the normal disk design. To do this I need to cut 8 pieces of MDF, to the size you wanted the tidy to be. When the disk was to be put inside the CNC machine we will need to put double sided tape on the back of each board (so once cut out not bits could fly out and disrupt the machine) and **nail each board to a sacrificial bed** (this was so if the drill went to far it wouldn't damage the machine). This process will need to be repeated 10 times so that we have 10 disks to glue together.



**Step 2:** Once the boards are set up correctly I will then have to change my ProDesktop design to "2D Design" then change my "2D Design" file and convert it to a FANUC (a FANUC file a special kind of file which converts my design into something readable for the Router) file so it can be used on the Denford Micro Router.



**Step 3:** Once all the MDF and ash disks are cut out I will glue the 9 regular disks together by applying glue to all the respective sides and then sliding each one onto all 3 dowels, once all 9 are tightly held onto each other, I will apply clamps (with wood layers either side of my project to avoid damaging the actual project). Once the project is clamped I will make sure all excess glue that will be leaking out is cleaned up as the glue could damage the project's quality.

Key: **Wear safety goggles and tuck in tie.**  
Tuck in tie.

# Plan of Making Continued

**Step 4:** Once all 9 of the regular disks are glued together I will then add the back disk by sawing down the dowels the correct length (as they might be too long) and then repeat what will be done to the 9 other disks to the back disk (gluing, clamping, cleaning).



**Step 5:** Once this is done, as shall be done with almost every step I must sand all parts of the project smooth, as if there are splinters on the project it will lower the quality.



**Step 6:** Once everything is dry I must sand any even sides/surfaces and apply the veneer. To apply the veneer I need to cut out an appropriate sized piece of veneer and then wrap it around the

**Step 6:** the circumference of my design so it shapes to the design. Once this is done I must then paint glue on the outside circumference of my design and inside layer of the veneer then wrap it around my project, wrap plastic around the veneer to hold it (and to avoid damage from the clamps) and apply strap clamps around the circumference of my project and veneer to hold it in place while it dries.



**Step 7:** The next step will be to apply matte black paint to the inside of the project (as gluing veneer onto the inside is not cost/time effective). To do this I must mask off the front of the front disk to avoid painting parts of the project which I do not want to paint. Once the paint is dry I will sand the inside shelves to make sure the surface is even, if necessary I might need to apply another coat of paint.

# Plan of Making Continued

**Step 8:** Once the paint is dry I must then add the balance block at the base of my design. To do this I shall find a roughly correct piece of ash then **cut it down to the size I prefer** (I could cut it to any length and it will still balance well, it depends on the person's preference), once this is done **I will sand the base of the block "slot" and then sand the balance block** so it won't look uneven. As with other steps I must then **apply the glue to both surfaces, clamp the block into the correct position and clean up any excess glue.**

Once this is done my teacher shall chamfer the balance block and chamfer the edges of the back of my design to improve the look of the edges. **I will then sand the edges** to even them out and give them a higher quality look.



**Step 9:** The final step of my project is to apply 10% Wood varnish to all of the ash on my project. To do this **I must take some wood varnish and pour it into a cup then I must measure out some white spirits by pouring it into the lid of the white spirits jug**, this equals out to be a correct amount of white spirits to varnish ratio, making 10% varnish. Once this is done **I must then apply a thin layer to all of the ash wood** and leave it to dry for a number of hours, if necessary more than one layer can be applied depending on how it has come out.

# The Making



Firstly, I began by cutting out 8 planks of MDF to make the bulk of my project. Once all 8 were cut out I had then had to cut out a back disk (made of ash), to do this I had to alter my design.

This was the most time consuming part of my project, especially because the machine made a few mistakes and I had to re-cut some MDF planks to make more disks.



After all 8 of my MDF disks were cut out, I had to cut out the front and back ash pieces of my design. This was the final cutting required, after this I would then glue them all together with glue and dowels.

# The Making

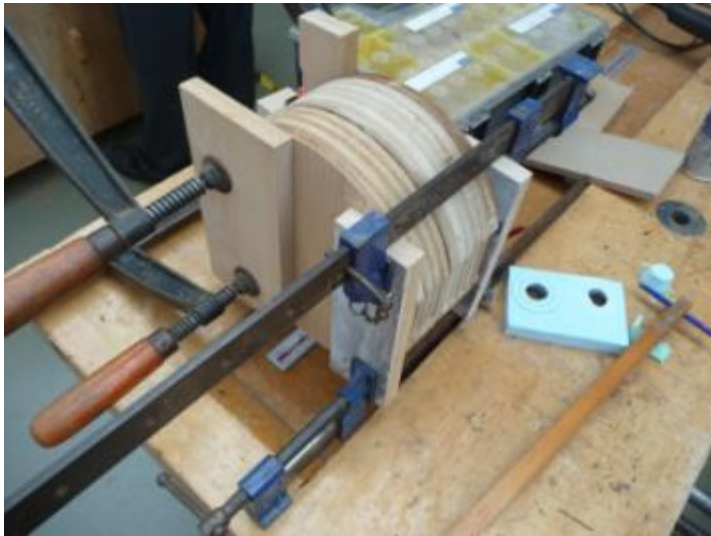

After all 10 of my varied disks were cut out I had to glue them together. First I glued together the 8 MDF disks then clamped them together. After clamping them together I had to make sure that any glue that was leaking out was cleaned off otherwise it could severely reduce the quality of my finished product.



After gluing the 8 MDF pieces together, I then had to glue the back and front MDF disks on, to do this, I had to accurately cut the dowels down to fit the back MDF disk, once this was done I glued the front and back disks on and clamped them with 2 pieces of wood.

# The Making



After gluing together all of the disks I then had to rap Ash Veneer around them, this means that the entire product gives the idea it is mad entirely of ash, when only the front and back disks are, while doing this it also makes my project a lot cheaper.

**My product was routed by the teacher at this point as the machine is difficult to use and needs expertise.**



The overall finish of the veneer was very nice as well as being a lot cheaper. I was unsure whether to do this on the inside of the product but decided against it as it would be too time consuming, to improve the look of the inside I decided to paint my product Matte Black.

**Once this was done I had to sand the veneer to remove the glue or any other substances that would lower the quality – this was a quality control check I had to do often.**

# The Making



After gluing on the veneer I began work on the inside of my tidy. Before, I decided that gluing on ash veneer to the inside would not be cost effective but also that it would be extremely difficult and would end with the quality I would be hoping for.

So I decided to paint the product matte black, this would be cost effective as well as coming out with a good quality outcome.



The outcome of the painting was quite successful, it ended with a high quality finish as well as not looking too unsightly around the edges of the actual ash wood. Once the paint was dry I had to sand it so make the surface even as well as apply a second coat for higher quality and to even up patches of the shelves.

The next step of my product was to create a stand for it to give it balance at the base of my product.

# The Making



After applying the matte black paint I then had to apply the ash stand to my product so that it would not fall backwards or forwards when pushed, as was in my template I had a section at the bottom of each disk design cut out so that I could fit this piece of wood.

Firstly I found an appropriate piece of ash and cut out it down to the correct measurements, then I chamfered it down and cut it to correct lengths.



The stand was applied to my product and then glued and clamped for 6 hours. Once it was dry I examined it and found it did it's job very effectively while still looking nice from the chamfered effect.

To improve the stand and the rest of my product up to higher standards it needed to have a coat of finish applied, this would give it a deeper color and overall would improve the quality of my finished product. **My balance block was routed at this point by the teacher as the machine requires expertise.**

# The Making



Before applying the coat of varnish to my product I had to sand all of the veneer and the ash pieces of any glue marks or other marks as this would greatly reduce the quality and outcome of my product.

As one of the final stages of making my product I had to apply a coat of 10% White spirit Varnish, as stated before this would apply a deep color to all of the ash wood on my product and enhancing this overall quality of my product.



Once the 10% Varnish was applied and left to dry for a number of the result was very pleasing and very much enhanced the color of the ash. This was my final step to finishing my tidy, once this was done I could clean up any parts of the project by sanding them or continue to add coats of 10% varnish as I see fit.

# My Opinion



Overall I very much liked the out come of my final design. While not being able to cover the inside of the design in Ash veneer, but having to paint it instead, it worked out quite well and still gave it a professional effect.

## **Modification**

What I would change about the project would be to find a more effective way of using my time, a direct problem from this would be that my disk cutting would of taken less time if the machine could fit 2 disks at once, while not exactly cutting my making time in half it would greatly reduce cutting time.

If I were to make a second one in a similar fashion that I have made my first I would make more exact measurements for the base of the product as well as prepping the ash veneer for the outside of my project, however this still did not take up much time. The main problem with my project would have been time management

# My Opinion/Examination

Painting the inside matte black was very modern as well as being cost and time effective, gluing in veneer to the insides could still of been an option, but would take a long time and might still not of had a good enough finish. Also it makes the tidy less bland as it has 2 colors involved in the design rather than just 1.

Simply having the front and back disk made of ash, and having veneer around the circumference of the MDF it gives the illusion that the entire design is made of ash when it's not, this gives it a high quality feel as well as saving money.

**General:** I feel my project has worked well and fit the target market I specified earlier; “market is anyone between 15-30 years old as these are the people who have multitudes of electronic gadgets. However my design can suit anyone of any age”. It can store a high number of cables/gadgets so it fits anyone with a surplus of gadgets.

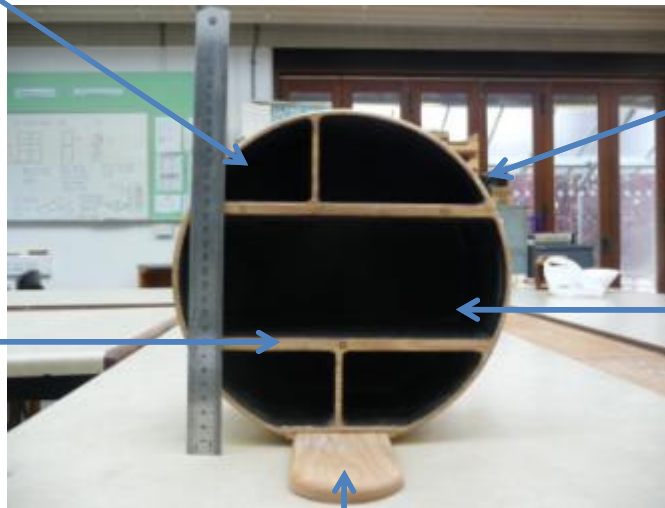

Curving the tidy while making it a much more interesting design also makes it seem very modern and less bland.

The inside of the tidy is very spacious, it in essence is a shelf, but one designed with the correct sizes for gadget's it gives the owner options for most kinds of small gadgets, rather than having a shelf that could only store specific things.

The stand while coming off as a clunky piece of wood that could be seen as ruining the design is modern and elegant, being made of ash it fits in perfectly and makes it seem like the product was well designed.

# The Design Task

**Our lifestyles are changing rapidly. Our homes contain an ever-increasing range of gadgets and equipment. It is fashionable to have multi-functional living spaces. We need creative, innovative products to help us organise our lives.**

## **'Design Task 10**

**People have an increasing number of gadgets and gizmos in their homes, such as mobile phones, iPods, remote controls, hand held computer games etc. Many of these products need chargers, memory cards, games etc. Design and make a gadget tidy.'**



As you can see the design task asks to create a tidy that can store a range of gadget's such as "mobile phones, iPods, remote controls, chargers", in the picture to the left all of these items are stored in tidy with there still being space for other products, such as a glasses case. The tidy can fit most ranges of gadgets so the owner has a lot more freedom for what they want to store.

I believe I have fulfilled exactly what the Design Task has asked me to; I've created a tidy that can store a range of gadgets, with an innovative and modern design.

# My Specifications

In my specifications I listed a few things:

- For it to be strong e.g. Made of wood
- Made of an “attractive” wood e.g. either ash or cherry and to be covered in ash veneer
- For it to be “smooth” e.g. No splinters (This was achieved by sanding after completing most of my steps to avoid any form of ‘low quality’ edges
- For it to be open and store a range of gadgets
- For it to be able to fit something large and specific like a sky remote.

As you can see while my design is able to fit a number of gadgets it can easily fit a sky remote with space to spare, so clearly it can fit remotes/large gadgets which was one of my main design specifications.

As stated above I wanted my design to be open and give the owner freedom of choice over what they wanted to store, (for example a sky remote) as also seen in the picture above this one I have succeeded in giving the owner freedom of choice in what they want to store by keeping my design open.

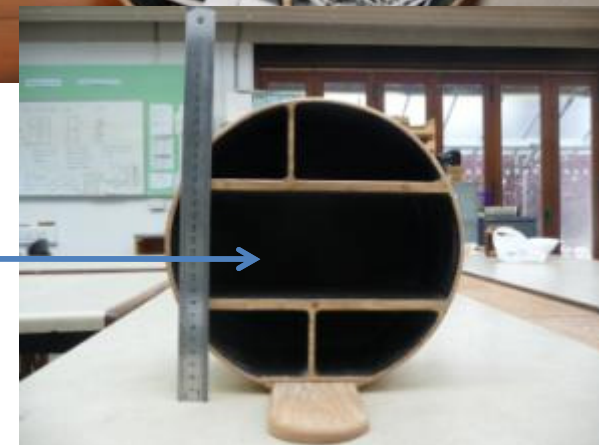

# My Specifications

- **Strong**

I want my tidy to be able to take a few accidental blows.

---



- **To be able to fit something as big as a sky remote**

This is the largest product that I would like to fit in my tidy so if it can fit a sky remote it can fit anything.

---



- **Open**

I don't want to have any kind of annoying drawers and it needs to be spacious.

---



- **Smooth, not have any splinters**

I wouldn't want my tidy to give out any sharp splinters.

---



- **Able to store anything, to not be too specific on which electrical gadgets I store**

After reviewing a lot of gadget storage units I find they are too specific in what products to store.

---



- **Attractive kind of wood**

I'm making it out of wood because of the environment, as wood is an environmentally sustainable material. I want the entire thing to be made of wood or covered in veneer.



# Testing



Upon testing it I was pleased to find that it could fit up to **15/16 cables/gadget's** (as well as

Being able to fit a sky remote) with space to spare, this is quite good as I would consider that to be a lot of gadgets. I discovered that it could fit a pleasantly high number of gadgets. Also with it being made of wood I know it would be quite durable, also having the stand meant that it wouldn't fall forwards or backwards, so I knew my tidy was perfect for the design task.

# Quality Control



Too unsure high quality I took a number of steps so that each part of my project was to a high standard throughout the making. This is how I did that:

- Clean up any mistakes done. A number of mistakes were made throughout the process of making my project, major ones being if the machine cut a disk incorrectly, I would have to recycle the disk and create a new one, this would take a lot of time but it was worth the time to keep the project up to a high standard.

Other mistakes that occurred could be with the painting or varnishing. If I painted or varnished the incorrect spot I would clean it up with white spirits or a paper towel, or in extreme cases have to sand that part of the project.

- After each part of my project was made I would sand it flat/smooth and make sure any rough edges were sanded down.

```
ERROR: undefined
OFFENDING COMMAND: ~
STACK:
```